

INTRODUCTION

The electric field, with which you are familiar from the previous experiments, usually causes a flow of charges, or simply an electric current. Ohm's Law says that a value of electric current in a piece of conductor depends linearly on the electric potential applied to it:

$$I = \frac{V}{R}$$

The constant R is called electrical resistance and it depends on the material forming the conductive element, its size and shape, but it does not depend on the applied potential.

Unlike fundamental Coulomb's and Gauss' Laws, which are always true, Ohm's Law is not universally true. For example, for semi-conducting elements like diodes Ohm's Law is not obeyed at all.

Elements which obey Ohm's Law are called resistors. Different resistors can be combined into a circuit. The flow of current through each element of the circuit is completely characterized by the total applied voltage and the resistance of the individual resistors. We will learn the rules for calculating the effective resistance of a composite circuit.

PURPOSE

- Study of elements that obey and violate Ohm's Law.
- Verification of the rules for resistors arranged in parallel or in series.

PRE-LAB ASSIGNMENTS

A. Readings:

Ohm's Law states that the current I through a piece of conductor depends linearly on the potential difference V between the two ends of the conductor. For objects that obey Ohm's Law we may define a constant quantity - electrical resistance R - which is simply the ratio of the potential difference and the current:

$$R = \frac{V}{I} \quad (1)$$

We measure resistance in units of:

$$[\Omega] \equiv [Ohm] = [Volt]/[Ampere].$$

For elements that don't obey Ohm's Law the resistance is not a constant quantity, thus it does not play a useful rule.

Elements which obey Ohm's Law are called resistors. What happens if we combine two such resistors together in *series*?

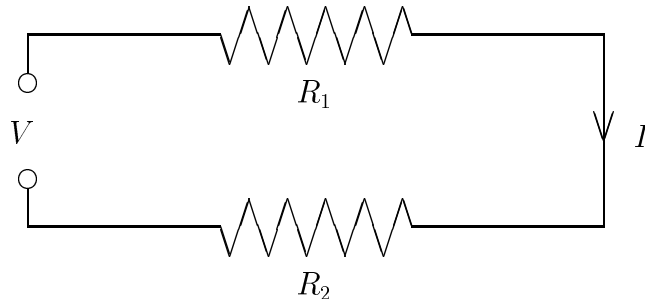

The current through them has to be the same, even if the resistors are different, because the current cannot be lost along its path. The total voltage drop across the two resistors will be the sum of the voltage drops across each of them:

$$V = V_1 + V_2 = I_1 R_1 + I_2 R_2 = I(R_1 + R_2)$$

From (1):

$$V = IR_{eff}$$

therefore, we have the *series rule* for the effective resistance R_{eff} :

$$R_{eff} = R_1 + R_2, \quad (2)$$

which can be easily generalized to an arbitrary number of resistors

$$R_{eff} = R_1 + R_2 + R_3 + R_4 + \dots \quad (3)$$

This rule simply says that n resistors connected in series are equivalent to a single resistor with the resistance R_{eff} .

If we connect resistors in *parallel* with the battery,

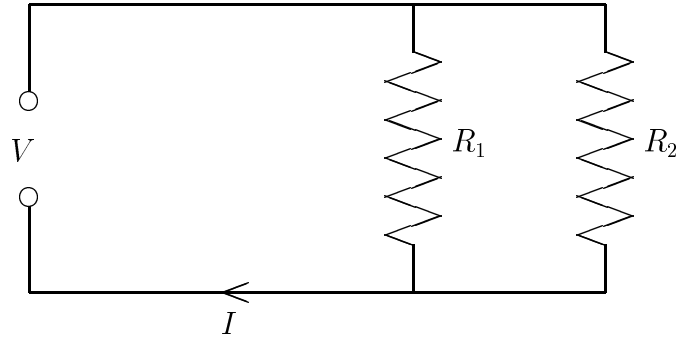

then the voltage drop across them will be the same, and equal to the voltage of the battery, while the total current will be the sum of the two currents flowing through each of them;

$$I = I_1 + I_2 = V/R_1 + V/R_2 = V(1/R_1 + 1/R_2) = V/R_{eff}.$$

Therefore, we have the *parallel rule*:

$$1/R_{eff} = 1/R_1 + 1/R_2 + 1/R_3 + \dots \quad (4)$$

for the effective resistance of the circuit consisting of the resistances R_1, R_2, R_3, \dots connected in parallel. For example, for two identical resistors with resistance R connected in parallel we have $R_{eff} = R/2$ (check it!), which makes sense because the current has twice as many ways to flow. You can think of two resistors in parallel as a two-lane highway which allows twice as many cars to flow during heavy traffic as would a single-lane road.

Circuits can be more complicated than resistors connected just in series or in parallel. However, it is often possible to think of a circuit as consisting of a few blocks, each being like a single effective resistor, connected in parallel or in series to the rest. Each block can be in turn separated into a few sub-blocks, and so on, until we break each sub-block down to a single resistor.

For instance, the circuit consisting of resistors connected like this

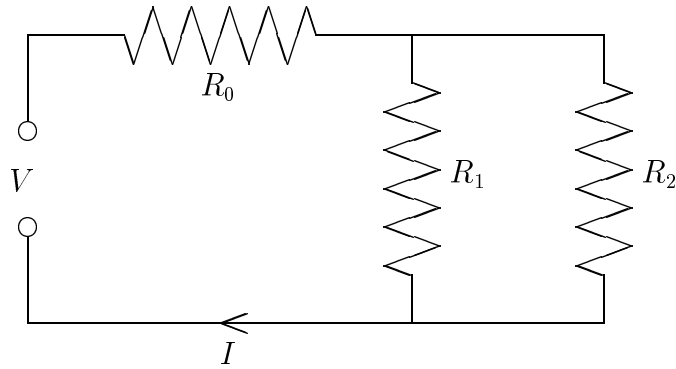

is equivalent to two effective resistors R_0 and R_p connected in series:

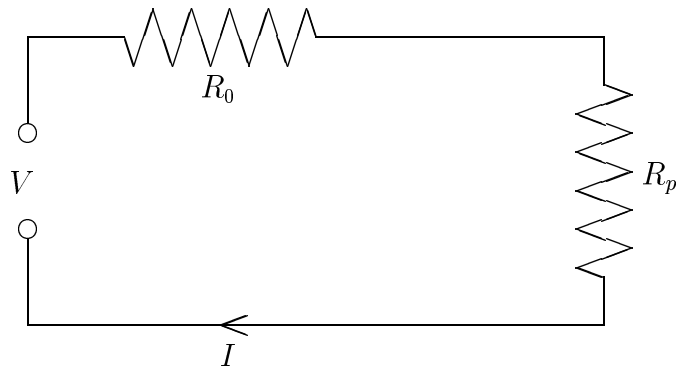

where according to formula (4):

$$1/R_p = 1/R_1 + 1/R_2, \quad \text{so, } R_p = \frac{R_1 R_2}{R_1 + R_2}, \quad \text{therefore, } R_{eff} = R_0 + \frac{R_1 R_2}{R_1 + R_2}.$$

B. Exercises:

Please answer the questions on Report Sheet IV-1, which will be collected at the *beginning* of the laboratory session and graded by your instructor.

LABORATORY ASSIGNMENTS

Materials Needed:

- Resistors: 2Ω , 220Ω , two 100Ω
- Diode (Experiment **B**)
- Rheostat
- 4.5V Battery
- Dual Channel Amplifier with voltage probes
- ULI computer interface box
- Voltmeter (for calibration only)
- Cables

Experiment A: *Ohm's Law*

The Task:

To observe linear dependence of I on V for a resistor and to measure its resistance, R .

Procedures

A-1. To verify Ohm's Law we need to measure the potential difference V across the resistor and the current I flowing through it for a wide range of V . The circuit to perform these measurements is shown here:

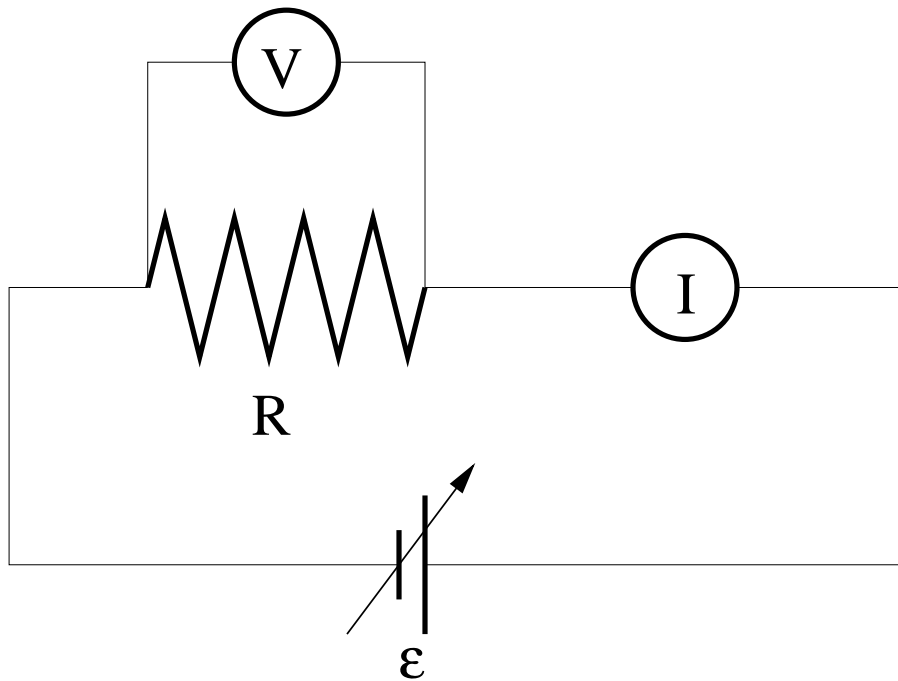

To vary V we need to use variable source of potential difference ∇ This can be achieved by connecting a battery to a rheostat as shown in figure below. Rheostat is a device

with which resistance can be varied. We will use a rheostat in which the resistance is controlled by a slider on top of the resistive cylinder. Although the battery will supply a constant potential difference of 4.5 Volts, whatever is connected to our battery-rheostat unit will receive the potential difference of $\epsilon = 4.5 - I \cdot R_{rheostat}$ (I is the current flowing through the rheostat). Change of $R_{rheostat}$ will imply change of ϵ .

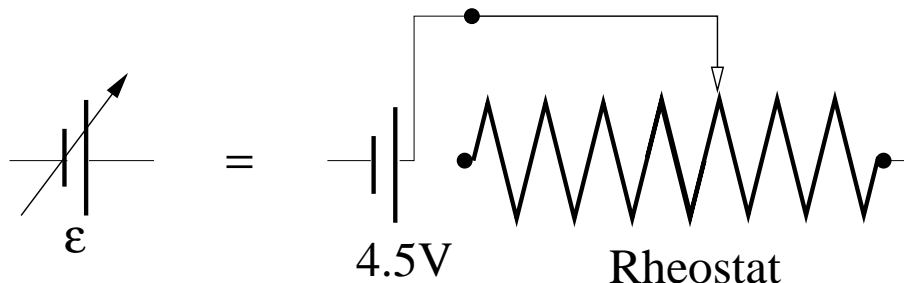

To measure the potential difference $\text{---}\text{v}\text{---}$ across the resistor, we will use the computerized voltage probe with the two leads connected to the two ends of the resistor.

Most of devices that measure current $\text{---}\text{i}\text{---}$ employ Ohm's Law and simply measure the potential difference V' across the known resistor as shown below. We will use 100Ω resistor, thus $I = V'/100\Omega$. You may be disturbed that we are using Ohm's Law here, even though the experiment itself is designed to verify Ohm's Law validity. Don't worry. There is no logical inconsistency. If the experiment shows that Ohm's Law works, we were right to employ it to measure the current. If the experiment fails to confirm Ohm's Law, we will conclude that the law failed either across the resistor under study or across the resistor used in the current measurement.

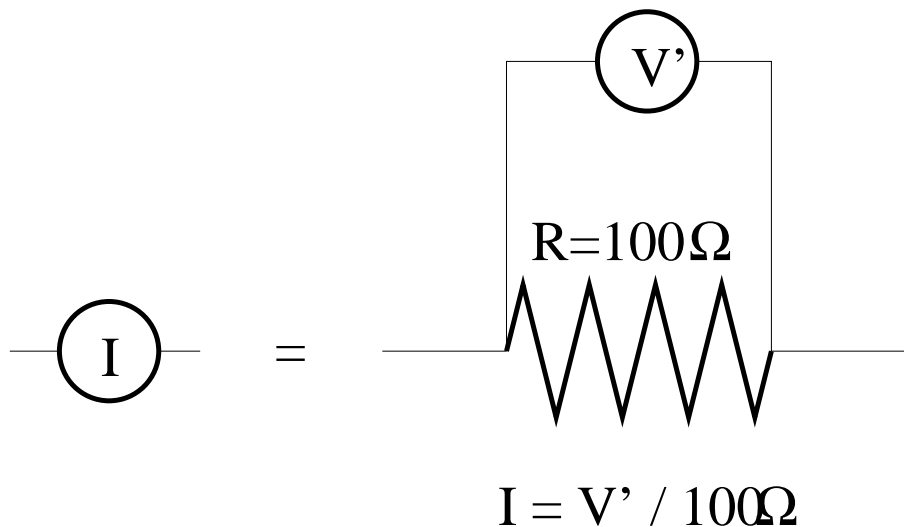

We will use two voltage probes in this experiment. Make sure the probes are connected to the Dual Channel Amplifier and that the latter is connected to the ULI interface box (DIN1 to DIN1, DIN2 to DIN2). Switch the interface box on. Start the computer, and click on the PHY222 icon to start the program. To load the proper initialization file, choose "Open..." from the "File" menu. Open the file "ohms" in PHY222 subdirectory.

In the first step you must check calibration of the voltage probes. The voltage read from probe 1 (2) is displayed as $V1 = (V2 =)$ below the graph area. They should read zero when directly connecting the red and black leads to each other. Measure voltage of a test battery with a hand-held voltmeter. Then connect the same battery to the voltage probe (the black lead to the “-” pole of the battery, the red lead to the “+” pole) and see if the computer reads a similar value. Notify the instructor if the computer does not read reasonable voltage values.

- A-2.** Connect one pole of the battery to the slider on the rheostat (there is a terminal at the end of the metal bar on which the slider moves). Connect 220Ω resistor to the other pole of the battery. Connect the other end of this resistor to 100Ω resistor which will be used for the current measurement. Finally connect the other end of the 100Ω resistor to one of the bottom terminals of the rheostat.

Connect the voltage probe 1 across the 220Ω resistor ($V1$ in the computer will be V from Fig. 1) and the voltage probe 2 across the 100Ω resistor. The latter voltage will be converted by the computer to the value of current I . Order of connecting black/red leads of the voltage probes matters and changes sign of the measured values. Connect the leads in a way that both $V1$ and $V2$ (or I) are positive.

- A-3.** Click on the “Collect” button. The computer will collect data for 10seconds. Vary the supplied potential by smoothly moving the slider on the rheostat. Make sure that you reach both extreme positions of the slider on each end of the rheostat. You can move back-and-forth between the two ends.

There are four graphs on your screen. The top left graph shows the voltage difference $V = V1$ across the studied 220Ω resistor as a function of time. The bottom left graph shows the current I ($I = V2/100\Omega$) flowing in our circuit as a function of time. The top right graph shows dependence of I on V . Finally, the bottom right plot shows how the ratio V/I changes with time.

Copy the I vs. V graph onto Report Sheet IV-2. Is it linear as expected from Ohm’s Law?

The other way to see if Ohm’s Law works is to look at the dependence of V/I on time. Since this ratio is simply the resistance of the resistor, it should be constant. Any deviations from flatness are due to the measurement inaccuracies.

Actual resistance of the resistor may be somewhat different from its nominal rating. We can determine the actual resistance from our data. For the best measurement of the resistance average the data from the V/I vs. Time graph by selecting it (click on it) and then going to “Analyze” menu and finally choosing “Statistics”. This should superimpose a box on your graph in which you can find the mean (i.e. average) value. Copy it to Report Sheet IV-2. How far is your measurement from the nominal value of the resistor?

- A-4.** Repeat the measurement for the second 100Ω resistor connected instead of the 220Ω resistor. Determine average value of R and also copy it to Report Sheet IV-2.

A-5. Now try to measure actual resistance of 2Ω resistor. You are likely to run into problems with the method we have been using so far, since the potential difference across the resistor is so small that it becomes comparable to the measurement inaccuracies and we cannot measure it very well. One possible solution is to move the slider on the rheostat only at the end that produces the highest potential difference (and current) across the resistor. Even better way is to perform a fit of a straight line to the I vs. V graph. Select this graph by clicking on it. Go to “Analyze” menu and select “Linear Fit”. This should superimpose the fitted line on your graph and a box with the fit results. The fitted function is “ $y = m x + b$ ” where in our case $y = I$, $x = V$ and the slope $m = 1/R$. Thus, you can determine resistance by inverting m . Since we graph the current in units of milliamperes (mA), to obtain resistance in units of Ohms you should calculate $R = 1000/m$.

Experiment B: Diode

The Task:

To illustrate that not all electric elements follow Ohm’s Law.

Procedures

- B-1.** Connect a diode instead of the resistor into our measurement circuit. Make the diode arrow point to the negative pole of the battery. Collect the data and copy I vs. V graph and V/I vs. time graph onto Report Sheet IV-3. Do not forget to indicate range of observed values on the I , V and V/I axes.
- B-2.** Change the direction in which the diode is connected to the circuit (the diode arrow pointing to the positive pole of the battery). Collect the data. Don’t be alarmed if the data look like a mess. Note down in Report Sheet IV-3 the maximal absolute value of the current through the diode you have obtained. Compare it to the maximal value of the current you have achieved with the diode connected the other way (i.e. in B-1).

Experiment C-F: Resistors Connected in Series and in Parallel

The Task:

To verify the rules for effective resistance of resistors connected in series and in parallel.

Procedures

If for any of configurations of resistors you are going to study, the effective resistance becomes small, use the fit method described in A-5 rather than averaging of the V/I measurements.

- C. Connect in series 220Ω and 100Ω resistors instead of the diode. The voltage probe 1 should be connected across both resistors. Collect the data for varying applied potential. From V/I vs. time graph calculate average effective resistance and note it down in Report Sheet IV-4. Calculate the expected effective resistance from the rule for the resistors connected in series. Use the measured rather than nominal values of the resistance for each resistor (from IV-2). Report your calculation in Report Sheet IV-4. How does the measured effective resistance compare with the calculated one?
- D. Now connect the same resistors in parallel. Collect the data for varying applied potential and determine average effective resistance. Calculate the expected effective resistance and report both in Report Sheet IV-4.
- E. Add 2Ω resistor in parallel to the other resistors. Before making any measurements or calculations make a rough guess of the effective resistance of the three resistors connected in parallel. Now make the measurement and the calculation (Report Sheet IV-4).
- F. Connect 2Ω resistor in series with 220Ω and 100Ω resistors connected in parallel. Make a rough guess of the effective resistance of the system of resistors. Now make the measurement and the calculation (Report Sheet IV-4).

REPORT SHEET IV-1

Date _____ Name _____

Instructor _____

PRE-LAB EXERCISES

Exercise 1.

At home, if you plug two lamps in the same double-outlet, are you connecting these lamps in series or in parallel? Explain.

Exercise 2.

Assume you have two 100Ω resistors, but need 50Ω resistor. Is there a way to connect the 100Ω resistors to get 50Ω ?

Exercise 3.

Calculate effective resistance of three resistors connected as shown.

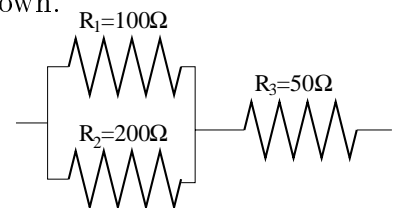

REPORT SHEET IV-2

Date _____ Name _____

Instructor _____ Partner(s) _____

A.

Current vs Potential (for 220Ω resistor)

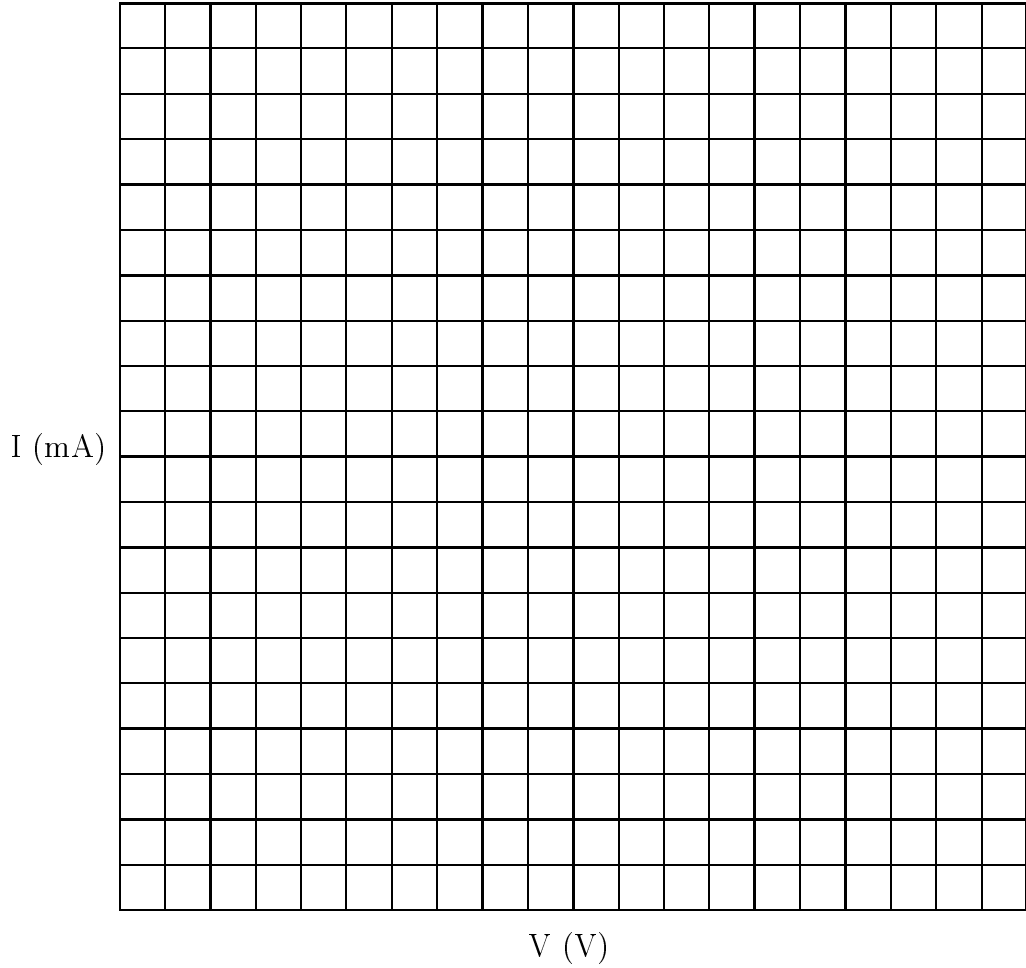

	Nominal resistance	Measured resistance
A-3	220Ω	
A-4	100Ω	
A-5	2Ω	

REPORT SHEET IV-3

Date _____

Name _____

Instructor _____

Partner(s) _____

B-1. Current vs. Potential

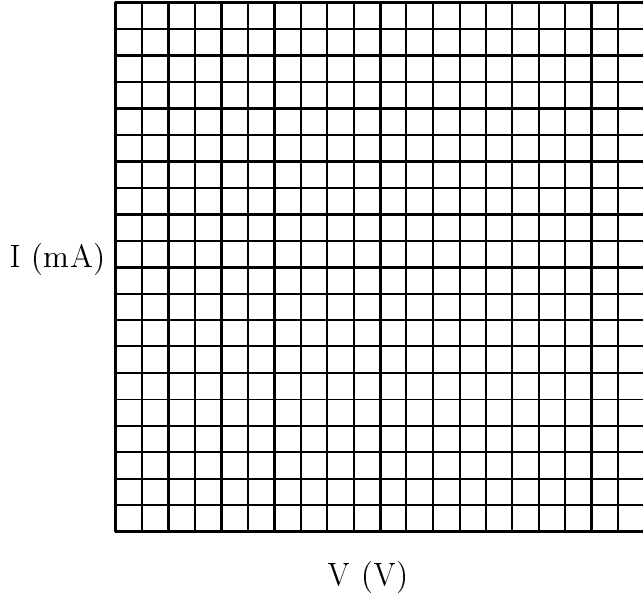

B-1

Does the diode fulfill Ohm's Law? Explain.

Does the diode have a constant resistance?

B-1. Resistance vs. Time

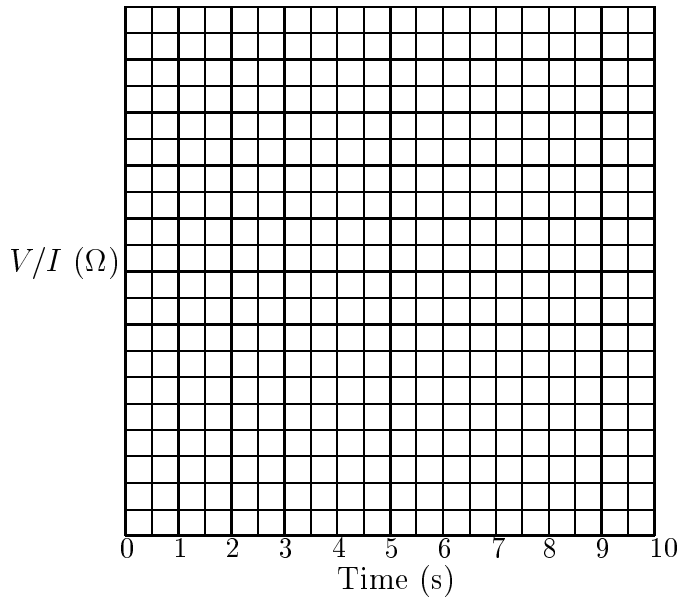

B-2.

Maximal absolute value of current for the reverse connections of the diode

$$|I|_{max} =$$

What can you say about value of the current through the diode in this case as compared to the maximal value obtained in B-1?

REPORT SHEET IV-4

Date _____ Name _____

Instructor _____ Partner(s) _____

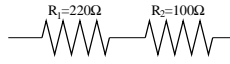
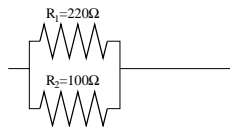
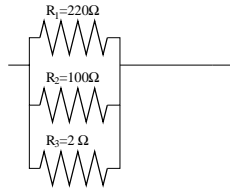
Experiment	Effective Resistance		
	Measured Value	Expected	
		Formula	Value
C 			
D 			
E 			
F 